



OPERATING INSTRUCTIONS

EN

Translation of the Original

HIPACE 80

Turbopump

Dear Customer,

Thank you for choosing a Pfeiffer Vacuum product. Your new turbopump is designed to support you by its performance, its perfect operation and without interfering your individual application. The name Pfeiffer Vacuum stands for high-quality vacuum technology, a comprehensive and complete range of top-quality products and first-class service. With this expertise, we have acquired a multitude of skills contributing to an efficient and secure implementation of our product.

Knowing that our product must not interfere with your actual work, we are convinced that our product offers you the solution that supports you in the effective and trouble-free execution of your individual application.

Please read these operating instructions before putting your product into operation for the first time. If you have any questions or suggestions, please feel free to contact info@pfeiffer-vacuum.de.

Further operating instructions from Pfeiffer Vacuum can be found in the [Download Center](#) on our website.

Disclaimer of liability

These operating instructions describe all models and variants of your product. Note that your product may not be equipped with all features described in this document. Pfeiffer Vacuum constantly adapts its products to the latest state of the art without prior notice. Please take into account that online operating instructions can deviate from the printed operating instructions supplied with your product.

Furthermore, Pfeiffer Vacuum assumes no responsibility or liability for damage resulting from the use of the product that contradicts its proper use or is explicitly defined as foreseeable misuse.

Copyright

This document is the intellectual property of Pfeiffer Vacuum and all contents of this document are protected by copyright. They may not be copied, altered, reproduced or published without the prior written permission of Pfeiffer Vacuum.

We reserve the right to make changes to the technical data and information in this document.

Table of contents

1	About this manual	7
1.1	Validity	7
	1.1.1 Applicable documents	7
	1.1.2 Product variants affected	7
1.2	Target group	7
1.3	Conventions	7
	1.3.1 Instructions in the text	7
	1.3.2 Pictographs	8
	1.3.3 Stickers on the product	8
	1.3.4 Abbreviations	9
1.4	Trademark proof	9
2	Safety	10
2.1	General safety instructions	10
2.2	Safety instructions	10
2.3	Safety precautions	14
2.4	Limits of use of the product	14
2.5	Proper use	15
2.6	Foreseeable improper use	15
2.7	Personnel qualification	15
	2.7.1 Ensuring personnel qualification	16
	2.7.2 Personnel qualification for maintenance and repair	16
	2.7.3 Advanced training with Pfeiffer Vacuum	16
3	Product description	17
3.1	Function	17
	3.1.1 Cooling	17
	3.1.2 Rotor bearing	17
	3.1.3 Drive	17
3.2	Scope of delivery	18
3.3	Identifying the product	18
	3.3.1 Product types	18
	3.3.2 Product features	18
4	Transportation and Storage	19
4.1	Transport	19
4.2	Storage	19
5	Installation	20
5.1	Preparatory work	20
5.2	Connecting the high vacuum side	20
	5.2.1 Requirements for the dimensioning of a counter flange	20
	5.2.2 Considering earthquake protection	21
	5.2.3 Using a splinter shield or protective screen	22
	5.2.4 Using the vibration compensator	22
	5.2.5 Mounting orientations	23
	5.2.6 Installation of ISO-KF flange	23
	5.2.7 Attaching ISO-K flange onto ISO-K	24
	5.2.8 Installation of ISO-K flange onto ISO-F	24
	5.2.9 Attaching CF flange to CF-F	25
5.3	Connecting the fore-vacuum side	27
5.4	Connecting accessories	28
5.5	Connecting the electrical supply	29
	5.5.1 Earthing the turbopump	29
	5.5.2 Establishing the electric connection	29
6	Operation	31

6.1	Commissioning	31
6.2	Operating modes	32
	6.2.1 Operation without operating unit	32
	6.2.2 Operation via multi-function connection "X3"	32
	6.2.3 Operation via Pfeiffer Vacuum display and control unit	32
	6.2.4 Operation via field bus	32
6.3	Switching on the turbopump	33
6.4	Operation monitoring	33
	6.4.1 Operating mode display via LED	33
	6.4.2 Temperature monitoring	34
6.5	Switching off and venting	34
	6.5.1 Switching off	34
	6.5.2 Venting	34
7	Maintenance	36
	7.1 General maintenance information	36
	7.2 Maintenance intervals and responsibilities	36
	7.3 Replacing the operating fluid reservoir	37
	7.3.1 Removing the operating fluid reservoir	37
	7.3.2 Installing the operating fluid reservoir	38
	7.4 Replacing the electronic drive unit	39
	7.5 Confirming the rotation speed specification	40
8	Decommissioning	42
	8.1 Shutting down for longer periods	42
	8.2 Recommissioning	42
	8.3 Disposing of the vacuum pump	43
9	Malfunctions	44
10	Service solutions from Pfeiffer Vacuum	46
11	Spare parts HiPace 80	48
12	Accessories	49
	12.1 Accessory information	49
	12.2 Ordering accessories	49
13	Technical data and dimensions	51
	13.1 General	51
	13.2 Technical data	51
	13.3 Dimensions	53
	Declaration of conformity	55

List of tables

Tbl. 1:	Abbreviations used in this document	9
Tbl. 2:	Permissible ambient conditions	15
Tbl. 3:	Product designation of Pfeiffer Vacuum HiPace turbopumps	18
Tbl. 4:	Turbopump features	18
Tbl. 5:	Requirements for the dimensioning of customer-specific high vacuum connection	21
Tbl. 6:	Effect of splinter shield or protective screen on pumping speed	22
Tbl. 7:	Factory setting of the electronic drive unit for turbopumps when delivered	31
Tbl. 8:	Behavior and meaning of the LEDs on the electronic drive unit	34
Tbl. 9:	Factory settings for delayed venting in turbopumps	35
Tbl. 10:	Characteristic nominal rotation speeds of the turbopumps	41
Tbl. 11:	Troubleshooting turbopumps	45
Tbl. 12:	Overview of the spare parts available for the HiPace 80	48
Tbl. 13:	Accessories	50
Tbl. 14:	Conversion table: Pressure units	51
Tbl. 15:	Conversion table: Units for gas throughput	51
Tbl. 16:	Technical data for HiPace 80 24 V	53

List of figures

Fig. 2:	Position of the labels on the product	8
Fig. 3:	HiPace 80 design	17
Fig. 4:	Example: Safety connections	22
Fig. 5:	Recommended alignment when using oil-sealed backing pumps	23
Fig. 6:	Flange connection ISO-KF to ISO-KF	23
Fig. 7:	Flange connection ISO-K to ISO-F, bracket screws	24
Fig. 8:	Flange connection CF-F, hexagon head screw and through hole	26
Fig. 9:	Flange connection CF-F, stud screw and tapped hole	26
Fig. 10:	Flange connection CF-F, stud screw and through hole	27
Fig. 11:	Example of fore-vacuum connection on HiPace 80	27
Fig. 12:	Example of accessory connection via adapter TCS 12	28
Fig. 13:	Example: Connecting the grounding cable	29
Fig. 14:	Connecting the electronic drive unit to a power supply pack	30
Fig. 15:	Removing the operating fluid reservoir	38
Fig. 16:	Installing the operating fluid reservoir	39
Fig. 17:	Electronic drive unit installation and removal	40
Fig. 18:	Spare parts HiPace 80	48
Fig. 19:	Dimensions HiPace 80 DN 63 ISO-K	53
Fig. 20:	Dimensions HiPace 80 DN 63 CF-F	53
Fig. 21:	Dimensions HiPace 80 DN 40 ISO-KF	54

1 About this manual



IMPORTANT

Read carefully before use.
Keep the manual for future consultation.

1.1 Validity

These operating instructions are for customers of Pfeiffer Vacuum. They describe the function of the designated product and provide the most important information for safe usage of the product. The descriptions comply with applicable directives. All information provided in these operating instructions refer to the current development status of the product. The documentation remains valid as long as the customer does not modify the product in any way.

1.1.1 Applicable documents

Document	Number
Operating instructions, "electronic drive unit" TC 110 standard	PT 0204 BN
Operating instructions for "electronic drive unit" TC 110 PB	PT 0245 BN
Operating instructions, electronic drive unit TC 110 E74	PT 0301 BN
Operating instructions for "electronic drive unit" TC 110 RS	PT 0351 BN
Declaration of conformity	Part of this document

You can find these documents in the [Pfeiffer Vacuum Download Center](#).

1.1.2 Product variants affected

- HiPace 80, DN 63 ISO-K, TC 110
- HiPace 80, DN 63 CF-F, TC 110
- HiPace 80, DN 40 ISO-KF, TC 110

1.2 Target group

These operating instructions are aimed at all persons performing the following activities on the product:

- Transportation
- Setup (Installation)
- Usage and operation
- Decommissioning
- Maintenance and cleaning
- Storage or disposal

The work described in this document is only permitted to be performed by persons with the appropriate technical qualifications (expert personnel) or who have received the relevant training from Pfeiffer Vacuum.

1.3 Conventions

1.3.1 Instructions in the text

Usage instructions in the document follow a general structure that is complete in itself. The required action is indicated by an individual step or multi-part action steps.

Individual action step

A horizontal, solid triangle indicates the only step in an action.

- ▶ This is an individual action step.

Sequence of multi-part action steps

The numerical list indicates an action with multiple necessary steps.

1. Step 1
2. Step 2
3. ...

1.3.2 Pictographs

Pictographs used in the document indicate useful information.



1.3.3 Stickers on the product

This section describes all the stickers on the product along with their meaning.

	<p>Rating plate The rating plate of the turbopump is located on the lower part of the vacuum pump.</p> <p>Rating plate of the electronic drive unit The electronic drive unit rating plate is located on the top</p>
	<p>Operating instructions note This sticker indicates that this operating instructions must be read before performing any tasks.</p>
	<p>Protection class This sticker describes protection class 1 for the product. Its placement indicates the position for the ground connection.</p>
	<p>Closure seal The product is sealed ex-factory. Damaging or removing a closure seal results in loss of the warranty.</p>

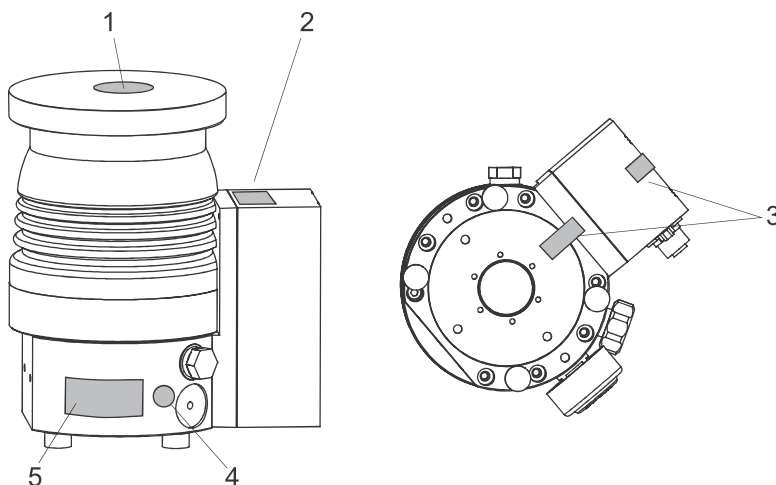

Fig. 2: Position of the labels on the product

- | | |
|---|---|
| 1 Operating instructions note | 4 Information regarding ground connection |
| 2 Rating plate of the electronic drive unit | 5 Rating plate of the turbopump |
| 3 Closure seal | |

1.3.4 Abbreviations

Abbreviation	Meaning in this document
CF	Flange: Metal-sealed connector in accordance with ISO 3669
d	Diameter value (in mm)
DC	Direct current
DCU	Display Control Unit.
DN	Nominal diameter as size description
f	Rotation speed value of a vacuum pump (frequency, in rpm or Hz)
HPU	Handheld Programming Unit.
HV	High vacuum flange, high vacuum side
ISO	Flange: Connector in accordance with ISO 1609 and ISO 2861
LED	Light emitting diode
PE	Earthed conductor (protective earth)
[P:xxx]	Electronic drive unit control parameters. Printed in bold as three-digit number in square brackets. Frequently displayed in conjunction with a short description. Example: [P:312] software version
S1	S1 switch on power supply pack
T	Temperature (in °C)
TC	Turbopump electronic drive unit (turbo controller)
TPS	Voltage supply (turbo power supply)
VV	Fore-vacuum flange, fore-vacuum connection
WAF	Width across flats
X3	15-pole D-Sub connecting socket on the turbopump electronic drive unit

Tbl. 1: Abbreviations used in this document

1.4 Trademark proof

- Torx® is a registered trading name of ACUMENT INTELLECTUAL PROPERTIES, LLC.
- Profibus® is a registered trading name of Profibus Nutzerorganisation e.V.

2 Safety

2.1 General safety instructions

This document includes the following 4 risk levels and 1 information level.

⚠ DANGER	
<p>Imminent danger Indicates a hazardous situation which, if not avoided, will result in death or serious injury.</p> <ul style="list-style-type: none"> ▶ Instructions on avoiding the hazardous situation 	
⚠ WARNING	
<p>Possibly imminent danger Indicates a hazardous situation which, if not avoided, could result in death or serious injury.</p> <ul style="list-style-type: none"> ▶ Instructions on avoiding the hazardous situation 	
⚠ CAUTION	
<p>Possibly imminent danger Indicates a hazardous situation which, if not avoided, could result in minor or moderate injury.</p> <ul style="list-style-type: none"> ▶ Instructions on avoiding the hazardous situation 	
NOTICE	
<p>Danger of property damage Notice is used to address practices not related to physical injury.</p> <ul style="list-style-type: none"> ▶ Instructions on avoiding property damage 	
<div style="border: 1px solid black; padding: 5px; display: inline-block;">  </div>	Notes, tips or examples indicate important information on the product or on this document.

2.2 Safety instructions

All safety instructions in this document are based on the results of the risk assessment carried out in accordance with Machinery Directive 2006/42/EC Annex I and EN ISO 12100 Section 5. Where applicable, all life cycle phases of the product were taken into account.

Risks during transport

⚠ WARNING
<p>Danger of serious injury due to falling objects Due to falling objects there is a risk of injuries to limbs through to broken bones.</p> <ul style="list-style-type: none"> ▶ Take particular care and pay special attention when transporting products manually. ▶ Do not stack the products. ▶ Wear protective equipment, e.g. safety shoes.

Risks during installation

⚠ DANGER**Danger to life from electric shock**

Power supply packs that are not specified or are not approved will lead to severe injury to death.

- ▶ Make sure that the power supply pack meets the requirements for double isolation between mains input voltage and output voltage, in accordance with IEC 61010 and IEC 60950.
- ▶ Make sure that the power supply pack meets the requirements in accordance with IEC 61010 and IEC 60950.
- ▶ Where possible, use original power supply packs or only power supply packs that correspond with the applicable safety regulations.

⚠ WARNING**Risk of cuts on moving, sharp-edged parts when reaching into the open high vacuum flange**

With the high vacuum flange open, access to sharp-edged parts is possible. A manual rotation of the rotor increases the danger situation. There is the risk of cuts, up to the separation of body parts (e.g. fingertips). There is a risk of hair and loose clothing being drawn in. Objects falling in destroy the turbopump during subsequent operation.

- ▶ Only remove the original protective covers immediately prior to connecting the high vacuum flange.
- ▶ Do not reach into the high vacuum connection.
- ▶ Wear protective gloves during installation.
- ▶ Do not start the turbopump with open vacuum connections.
- ▶ Always carry out the mechanical installation before electrical connection.
- ▶ Prevent access to the high vacuum connection of the turbopump from the operator side (e.g. open vacuum chamber).

⚠ WARNING**Risk of injury caused by the turbopump breaking away with the vibration compensator in the event of a malfunction**

Sudden jamming of the rotor generates high destructive torques in accordance with ISO 27892. When using a vibration compensator, this will probably lead to the turbopump being sheared off in use. The energy that this would release could throw the entire turbopump or shattered pieces from its interior through the surrounding space. Potentially dangerous gases can escape. There is a risk of very serious injuries, including death, and extensive property damage.

- ▶ Take suitable safety precautions on-site for the compensation of the occurring torques.
- ▶ Before installing a vibration compensator, you must first of all contact Pfeiffer Vacuum.

⚠ WARNING**Danger to life from poisoning where toxic process media leak from damaged connections**

Sudden twisting of the turbopump in the event of a fault causes fittings to accelerate. There is the risk of damaging on-site connections (e.g., fore-vacuum line) and resulting leaks. This results in leakage of process media. In processes involving toxic media, there is a risk of injury and danger to life due to poisoning.

- ▶ Keep masses connected to the turbopump as low as possible.
- ▶ Use flexible lines to connect to the turbopump where necessary.

⚠ WARNING**Risk of danger to life through missing mains disconnection device**

The vacuum pump and electronic drive unit are **not** equipped with a mains disconnection device (mains switch).

- ▶ Install a mains disconnection device according to SEMI-S2.
- ▶ Install a circuit breaker with an interruption rating of at least 10,000 A.

⚠ WARNING

Risk of injury due to incorrect installation

Dangerous situations may arise from unsafe or incorrect installation.

- ▶ Do not carry out your own conversions or modifications on the unit.
- ▶ Ensure the integration into an Emergency Off safety circuit.

⚠ WARNING

Danger of cut injuries from unexpected start up.

The use of mating plugs of the electronic drive unit (accessories) enables the automatic run-up of the vacuum pump as soon the power is turned on. Attaching mating plugs before or during the installation leads to the movement of parts hence the risk of cut injuries by sharp-edged in the exposed high vacuum flange.

- ▶ Only connect mating plugs after the mechanical installation.
- ▶ Only switch on the vacuum pump immediately prior to operation.

Risks during operation

⚠ WARNING

Risk of burns on hot surfaces when using additional equipment for heating during operation

The use of additional equipment for heating the vacuum pump or for optimizing the process generates very high temperatures on surfaces that can be touched. There is a risk of burning.

- ▶ If necessary, set up a contact guard.
- ▶ If necessary, apply the warning stickers provided for this at the danger points.
- ▶ Ensure adequate cooling down before working on the vacuum pump or in its vicinity.
- ▶ Wear protective equipment, e.g., gloves.

⚠ WARNING

Risk of serious injury in the event of vacuum pump destruction due to over pressure

Gas entry with very high over pressure results in destruction of the vacuum pump. There is a risk of serious injury due to ejected objects.

- ▶ Never exceed the permissible 1500 hPa (absolute) inlet pressure on the suction side or the venting and sealing gas connection.
- ▶ Make sure that high, process-related over pressures cannot directly enter the vacuum pump.

⚠ CAUTION

Risk of injuries due to contact with vacuum when venting

While venting the vacuum pump there is a risk of minor injuries due to the direct contact of body parts with the vacuum, e.g. hematomas.

- ▶ Do not fully unscrew the venting screw out of the housing during venting.
- ▶ Keep a distance from automatic venting device, such as venting valves.

Risks during maintenance and decommissioning

⚠ WARNING

Danger to life from electric shock during maintenance and service work

The device is only completely de-energized when the mains plug has been disconnected and the turbopump is at a standstill. There is a danger to life from electric shock when making contact with live components.

- ▶ Before performing all work, switch off the main switch.
- ▶ Wait until the turbopump comes to a standstill (rotation speed =0).
- ▶ Remove the mains plug from the device.
- ▶ Secure the device against unintentional restarting.

⚠ WARNING**Risk of cuts on moving, sharp-edged parts when reaching into the open high vacuum connection**

Incorrect handling of the turbopump before maintenance work results in hazardous situations with risk of injury. There is a risk of cuts from accessing sharp-edged, rotating parts when removing the turbopump.

- ▶ Wait until the turbopump comes to a standstill (rotation speed $f=0$).
- ▶ Switch the turbopump off properly.
- ▶ Secure the turbopump against re-start.
- ▶ Seal open connections immediately following removal, using the original protective cover.

⚠ WARNING**Health hazard through poisoning from toxic contaminated components or devices**

Toxic process media result in contamination of devices or parts of them. During maintenance work, there is a risk to health from contact with these poisonous substances. Illegal disposal of toxic substances causes environmental damage.

- ▶ Take suitable safety precautions and prevent health hazards or environmental pollution by toxic process media.
- ▶ Decontaminate affected parts before carrying out maintenance work.
- ▶ Wear protective equipment.

⚠ WARNING**Risk of poisoning from contact with harmful substances**

The operating fluid reservoir and parts of the turbopump may contain toxic substances from pumped media.

- ▶ Decontaminate affected parts before carrying out maintenance work.
- ▶ Prevent health hazards or environmental impacts with adequate safety precautions.
- ▶ Observe the operating fluid safety data sheet.
- ▶ Dispose of the operating fluid reservoir according to applicable regulations.

Risks in the event of malfunctions**⚠ WARNING****Danger to life from the turbopump breaking away in the event of a fault**

Sudden jamming of the rotor generates high destructive torques in accordance with ISO 27892. If the turbopump is **not** properly secured, it can shear off. The energy that this would release could throw the entire turbopump or shattered pieces from its interior through the surrounding space. Potentially dangerous gases can escape. There is a risk of very serious injuries, including death, and extensive property damage.

- ▶ Follow the installation instructions for this turbopump.
- ▶ Observe the requirements regarding stability and design of the counter flange.
- ▶ Use only original accessories or fixing material approved by Pfeiffer Vacuum for the installation.

⚠ WARNING**Risk of injury caused by the turbopump breaking away with the vibration compensator in the event of a malfunction**

Sudden jamming of the rotor generates high destructive torques in accordance with ISO 27892. When using a vibration compensator, this will probably lead to the turbopump being sheared off in use. The energy that this would release could throw the entire turbopump or shattered pieces from its interior through the surrounding space. Potentially dangerous gases can escape. There is a risk of very serious injuries, including death, and extensive property damage.

- ▶ Take suitable safety precautions on-site for the compensation of the occurring torques.
- ▶ Before installing a vibration compensator, you must first of all contact Pfeiffer Vacuum.

⚠ WARNING

Danger to life from poisoning where toxic process media leak from damaged connections

Sudden twisting of the turbopump in the event of a fault causes fittings to accelerate. There is the risk of damaging on-site connections (e.g., fore-vacuum line) and resulting leaks. This results in leakage of process media. In processes involving toxic media, there is a risk of injury and danger to life due to poisoning.

- ▶ Keep masses connected to the turbopump as low as possible.
- ▶ Use flexible lines to connect to the turbopump where necessary.

2.3 Safety precautions

i

Duty to provide information on potential dangers

The product holder or user is obliged to make all operating personnel aware of dangers posed by this product.

Every person who is involved in the installation, operation or maintenance of the product must read, understand and adhere to the safety-related parts of this document.

i

Infringement of conformity due to modifications to the product

The Declaration of Conformity from the manufacturer is no longer valid if the operator changes the original product or installs additional equipment.

- Following the installation into a system, the operator is required to check and re-evaluate the conformity of the overall system in the context of the relevant European Directives, before commissioning that system.

General safety precautions when handling the product

- ▶ Observe all applicable safety and accident prevention regulations.
- ▶ Check that all safety measures are observed at regular intervals.
- ▶ Do not expose body parts to the vacuum.
- ▶ Always ensure a secure connection to the earthed conductor (PE).
- ▶ Never disconnect plug connections during operation.
- ▶ Observe the above shutdown procedures.
- ▶ Before working on the high vacuum connection, wait until the rotor has stopped completely (rotation speed $f = 0$).
- ▶ Never put the device into operation with the high vacuum connection open.
- ▶ Keep lines and cables away from hot surfaces ($> 70^\circ\text{C}$).
- ▶ Never fill or operate the unit with cleaning agents or cleaning agent residues.
- ▶ Do not carry out your own conversions or modifications on the unit.
- ▶ Observe the unit protection class prior to installation or operation in other environments.

2.4 Limits of use of the product

Installation location	weatherproof (internal space)
Air pressure	750 hPa to 1060 hPa
Installation altitude	max. 5000 m
Rel. air humidity	max. 80%, at $T < 31^\circ\text{C}$, up to max. 50% at $T < 40^\circ\text{C}$
Protection class	III
Excess voltage category	II
Permissible protection degree	IP54
Degree of contamination	2
Ambient temperature	5 °C to 30 °C with convection cooling without gas throughput 5°C to 35°C with air cooling 5°C to 40°C with water cooling

Permissible surrounding magnetic field for air cooling	3.3 mT
Permissible surrounding magnetic field for water cooling	3.8 mT
Maximum irradiated thermal output for air cooling	0.9 W
Maximum irradiated thermal output for water cooling	1.2 W
Maximum permissible rotor temperature of the turbopump	90 °C

Tbl. 2: Permissible ambient conditions



Notes on ambient conditions

The specified permissible ambient temperatures apply to operation of the turbopump at maximum permissible backing pressure or at maximum gas throughput, depending on the cooling type. The turbopump is intrinsically safe thanks to redundant temperature monitoring.

- The reduction in backing pressure or gas throughput permits operation of the turbopump at higher ambient temperatures.
- If the maximum permissible operating temperature of the turbopump is exceeded, the electronic drive unit first reduces the drive output and then switches it off where necessary.

2.5 Proper use

- ▶ Use the turbopump only for generating vacuum.
- ▶ Use the turbopump only in combination with a suitable backing pump that can deliver up to the required maximum fore-vacuum pressure.
- ▶ Use the turbopump only in closed indoor areas.
- ▶ Use the turbopump only for the evacuation of dry and inert gases.

2.6 Foreseeable improper use

Improper use of the product invalidates all warranty and liability claims. Any use that is counter to the purpose of the product, whether intentional or unintentional, is regarded as misuse, in particular:

- Establishing the voltage supply without correct installation
- Installation with non-specified fastening material
- Pumping explosive media
- Pumping of corrosive media
- Pumping of condensing vapors
- Pumping of fluids
- Pumping of dust
- Operation with impermissible high gas throughput
- Operation with impermissible high fore-vacuum pressure
- Operation with excessively high irradiated heat output
- Operation in impermissible high magnetic fields
- Operation in an incorrect gas mode
- Venting with impermissible high venting rates
- Use for pressure generation
- Use in areas with ionizing radiation
- Operation in explosion-hazard areas
- Use in systems in which sporadic loads and vibrations or periodic forces act on the device
- The causing of hazardous operating conditions by a presetting on the electronic drive unit that is contrary to the process
- Use of accessories or spare parts that are not listed in these instructions

2.7 Personnel qualification

The work described in this document may only be carried out by persons who have appropriate professional qualifications and the necessary experience or who have completed the necessary training as provided by Pfeiffer Vacuum.

Training people

1. Train the technical personnel on the product.
2. Only let personnel to be trained work with and on the product when under the supervision of trained personnel.
3. Only allow trained technical personnel to work with the product.
4. Before starting work, make sure that the commissioned personnel have read and understood these operating instructions and all applicable documents, in particular the safety, maintenance and repair information.

2.7.1 Ensuring personnel qualification

Specialist for mechanical work

Only a trained specialist may carry out mechanical work. Within the meaning of this document, specialists are people responsible for construction, mechanical installation, troubleshooting and maintenance of the product, and who have the following qualifications:

- Qualification in the mechanical field in accordance with nationally applicable regulations
- Knowledge of this documentation

Specialist for electrotechnical work

Only a trained electrician may carry out electrical engineering work. Within the meaning of this document, electricians are people responsible for electrical installation, commissioning, troubleshooting, and maintenance of the product, and who have the following qualifications:

- Qualification in the electrical engineering field in accordance with nationally applicable regulations
- Knowledge of this documentation

In addition, these individuals must be familiar with applicable safety regulations and laws, as well as the other standards, guidelines, and laws referred to in this documentation. The above individuals must have an explicitly granted operational authorization to commission, program, configure, mark, and earth devices, systems, and circuits in accordance with safety technology standards.

Trained individuals

Only adequately trained individuals may carry out all works in other transport, storage, operation and disposal fields. Such training must ensure that individuals are capable of carrying out the required activities and work steps safely and properly.

2.7.2 Personnel qualification for maintenance and repair



Advanced training courses

Pfeiffer Vacuum offers advanced training courses to maintenance levels 2 and 3.

Adequately trained individuals are:

- **Maintenance level 1**
 - Customer (trained specialist)
- **Maintenance level 2**
 - Customer with technical education
 - Pfeiffer Vacuum service technician
- **Maintenance level 3**
 - Customer with Pfeiffer Vacuum service training
 - Pfeiffer Vacuum service technician

2.7.3 Advanced training with Pfeiffer Vacuum

For optimal and trouble-free use of this product, Pfeiffer Vacuum offers a comprehensive range of courses and technical trainings.

For more information, please contact [Pfeiffer Vacuum technical training](#).

3 Product description

3.1 Function

The turbopump forms a compact unit with the electronic drive unit. Pfeiffer Vacuum power supply packs provide the voltage supply.

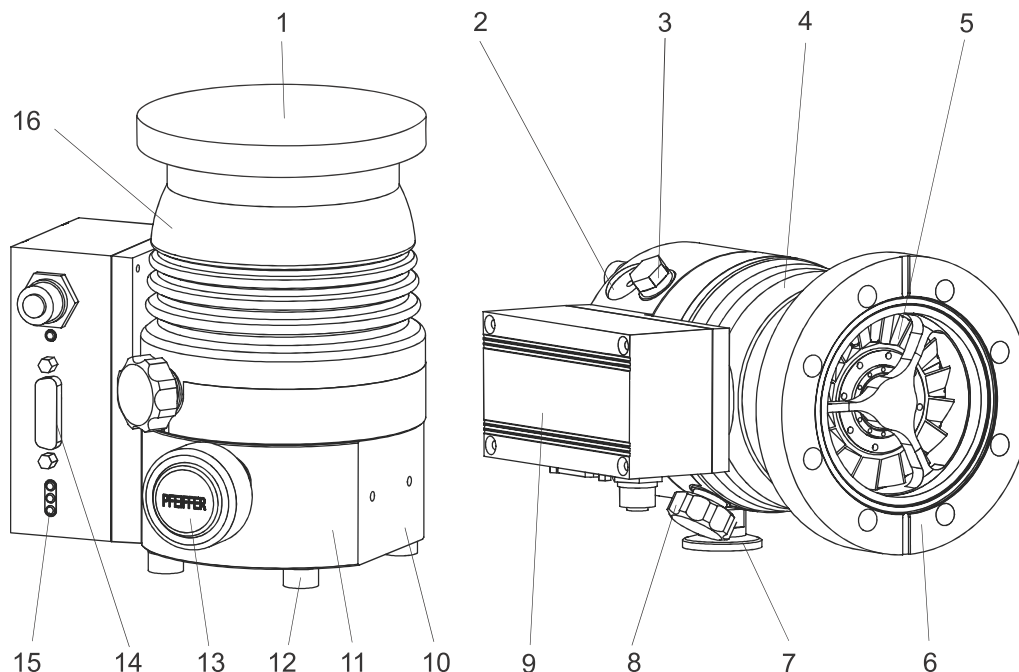

Fig. 3: HiPace 80 design

- | | |
|---|--|
| 1 Protective cover for the high vacuum connection | 9 Electronic drive unit TC 110 |
| 2 Ground terminal | 10 Mounting surface for water cooling |
| 3 Sealing gas connection | 11 Pump base |
| 4 Pump housing, stainless steel | 12 Rubber-metal bumper |
| 5 Turbo rotor | 13 Protective cover for the fore-vacuum connection |
| 6 High vacuum connection, here for example DN 63 CF-F | 14 Multifunction connection "X3" |
| 7 Fore-vacuum connection, DN 16 ISO-KF | 15 LED operating mode display |
| 8 Venting screw | 16 Pump housing, aluminum |

3.1.1 Cooling

- Convection cooling
- Air cooling (optional)
- Water cooling (optional)

The electronic drive unit automatically regulates the drive power down in the event of excessive temperatures.

3.1.2 Rotor bearing

Hybrid-bearing turbopump

- High vacuum side: wear-free permanent magnetic bearing
- Fore-vacuum side: ball bearing with ceramic balls

Permanent lubrication of the rotor bearing on the fore-vacuum side is ensured by an operating fluid reservoir.

3.1.3 Drive

- TC 110 electronic drive unit

3.2 Scope of delivery

- Turbopump with electronic drive unit
- Protective cover for the high vacuum connection
- Protective cover for the fore-vacuum connection
- Operating instructions

3.3 Identifying the product

- ▶ To ensure clear identification of the product when communicating with Pfeiffer Vacuum, always keep all of the information on the rating plate to hand.
- ▶ Learn about certifications through test seals on the product or at www.certipedia.com with company ID no. 000021320.

3.3.1 Product types

The product designation of Pfeiffer Vacuum turbopumps from the HiPace series is composed of the family name, the size (which is based on the pumping speed of the vacuum pump) and, if required, an additional feature description.

Family	Size/model	Property, attribute, feature
HiPace	10 to 2800	none = Standard version
		mini = Compact version
		U = Overhead version
		C = Corrosive gas version
		P = Process
		M = Active magnetic bearing
		T = Temperature management
		Plus = Low vibration, low magnetic field
		E = High efficiency
		H = High compression
		I = Ion implantation

Tbl. 3: Product designation of Pfeiffer Vacuum HiPace turbopumps

3.3.2 Product features

Feature	Version		
	HV flange	DN 63 ISO-K	DN 63 CF-F
Flange material	Aluminium	Stainless steel	Aluminium

Tbl. 4: Turbopump features

4 Transportation and Storage

4.1 Transport

WARNING

Danger of serious injury due to falling objects

Due to falling objects there is a risk of injuries to limbs through to broken bones.

- ▶ Take particular care and pay special attention when transporting products manually.
- ▶ Do not stack the products.
- ▶ Wear protective equipment, e.g. safety shoes.



We recommend

Pfeiffer Vacuum recommends keeping the transport packaging and original protective cover.

Instructions for safe transport

- ▶ Transport the turbopump only within the permissible temperature limits.
- ▶ Observe weight specified on the rating plate.
- ▶ Where possible, always transport or ship the turbopump in its original packaging.
- ▶ Always carry the turbopump with both hands.
- ▶ Remove the protective cover only immediately prior to installation.

4.2 Storage



We recommend

Pfeiffer Vacuum recommends storing the products in their original transport packaging.

Storing the turbopump

1. Seal all flange openings with the original protective caps.
2. Seal all other connections (e.g. venting connection) with the corresponding original parts.
3. Store the turbopump only indoors within the permissible temperature limits.
4. In rooms with humid or aggressive atmospheres: Hermetically seal the turbopump together with a drying agent in a plastic bag.

5 Installation

The installation of the turbopump and its fastening is of outstanding importance. The rotor of the turbopump revolves at very high speed. In practice it is not possible to exclude the risk of the rotor touching the stator (e.g. due to the penetration of foreign bodies into the high vacuum connection). The kinetic energy released acts on the housing and on the anchoring of the turbopump within fractions of a second.

Comprehensive tests and calculations conforming to ISO 27892 confirm the safety of the turbopump both against crashes (destruction of the rotor blade) and against bursting (breakage of the rotor shaft). The experimental and theoretical results are expressed in safety measures and recommendations for the correct and safe fastening of the turbopump.

5.1 Preparatory work

⚠ WARNING

Risk of cuts on moving, sharp-edged parts when reaching into the open high vacuum flange

With the high vacuum flange open, access to sharp-edged parts is possible. A manual rotation of the rotor increases the danger situation. There is the risk of cuts, up to the separation of body parts (e.g. fingertips). There is a risk of hair and loose clothing being drawn in. Objects falling in destroy the turbopump during subsequent operation.

- ▶ Only remove the original protective covers immediately prior to connecting the high vacuum flange.
- ▶ Do not reach into the high vacuum connection.
- ▶ Wear protective gloves during installation.
- ▶ Do not start the turbopump with open vacuum connections.
- ▶ Always carry out the mechanical installation before electrical connection.
- ▶ Prevent access to the high vacuum connection of the turbopump from the operator side (e.g. open vacuum chamber).

General notes for the installation of vacuum components

- ▶ Choose an installation location that permits access to the product and to supply lines at all times.
- ▶ Observe the ambient conditions given for the area of use.
- ▶ Provide the highest possible level of cleanliness during assembly.
- ▶ Ensure that flange components during installation are grease-free, dust-free and dry.

Select the installation location

1. Observe the instructions for transport to the installation location.
2. Make sure that there are sufficient cooling options for the turbopump.
3. Install suitable shielding if the surrounding magnetic fields exceed the permissible levels.
4. Install suitable shielding so that the irradiated thermal output does not exceed the permissible values when high temperatures occur due to the process.
5. Observe the permissible temperatures for the vacuum connection.

5.2 Connecting the high vacuum side

5.2.1 Requirements for the dimensioning of a counter flange

NOTICE

Risk of damage due to incorrect counter flange design

Unevenness on the operator-side counter flange results in stresses in the vacuum pump housing, even when properly attached. This can produce leakage or negative changes in running characteristics.

- ▶ Adhere to the shape tolerances for the counter flange.
- ▶ Observe the maximum flatness deviations over the entire surface.



Superstructural parts and fittings on the high vacuum connection

Installing superstructural parts and fittings to the high vacuum connection is the responsibility of the operating company. The loading capacity of the high vacuum flange is specific for the turbopump used.

- The total weight of superstructural parts must not exceed the maximum axial values specified.
- Make sure that all the torques generated if the rotor blocks suddenly, are absorbed by the system on the operator side and the high vacuum connection.
- Only use the approved mounting kits of Pfeiffer Vacuum for the high vacuum connection of the turbopump.

Parameter	HiPace 80
Maximum torque occurring in the event of a burst ¹⁾	620 Nm
Maximum permissible axial load on the high vacuum flange ²⁾	200 N (equivalent to 20 kg)
Flatness	± 0.05 mm
Minimum tensile strength of the flange material in all operating states in relation to the engagement depth of the fixing screws	170 N/mm ² at 2.5 x d 270 N/mm ² at 1.5 x d
Maximum permissible surrounding magnetic field	3.3 mT 3.8 mT (water cooling)
Maximum permissible irradiated thermal output	0.9 W 1.2 W (water cooling)
Maximum permissible rotor temperature	90 °C

Tbl. 5: Requirements for the dimensioning of customer-specific high vacuum connection

Important information for correct installation

- ▶ Only use the approved mounting kits of Pfeiffer Vacuum for the high vacuum connection of the turbopump.

5.2.2 Considering earthquake protection

NOTICE

Vacuum pump damage caused by external vibrations

In the event of earthquakes or other external vibrations, there is the risk of the rotor coming into contact with the safety bearings, or the housing wall touching the turbopump. This can produce mechanical loads up to and including destruction of the turbopump.

- ▶ Make sure that all flange and safety connections absorb the resulting forces.
- ▶ Secure the vacuum chamber against displacement or tipping.

1) The theoretically calculated torque in the event of a burst (rotor shaft breakage) according to ISO 27892 was not reached in any experimental test.
 2) A one-sided load is not permitted.

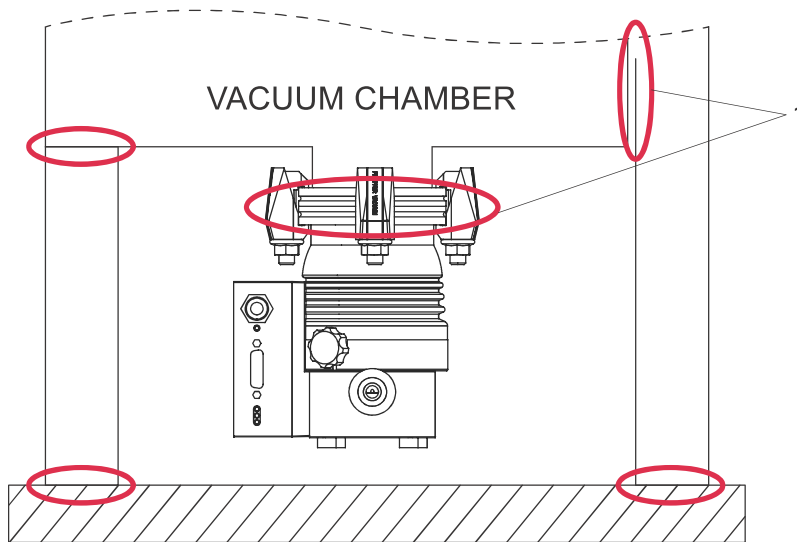

Fig. 4: Example: Safety connections

1 Safety connections, customer-side

5.2.3 Using a splinter shield or protective screen

Pfeiffer Vacuum centering rings with splinter shield or protective screen in the high vacuum flange protect the turbopump against foreign matter from the vacuum chamber. The pumping speed of the turbopump reduces according to the passage guide values and the size of the high vacuum flange.

Flange size	Reduced pumping speed in % for the gas type			
	H ₂	He	N ₂	Ar
Splinter shield DN 40	6	9	17	18
Splinter shield DN 63	3	6	15	16
Protective screen DN 63	1	1	4	4

Tbl. 6: Effect of splinter shield or protective screen on pumping speed

Procedure

1. With ISO flanges, use centering rings with protective screen or splinter shield.
2. For CF flanges, always insert protective screen or splinter shield with the clamping lugs pointing towards the rotor in the high vacuum flange.

5.2.4 Using the vibration compensator

Pfeiffer Vacuum vibration compensators are suitable for use on vibration-sensitive systems.

WARNING

Risk of injury caused by the turbopump breaking away with the vibration compensator in the event of a malfunction

Sudden jamming of the rotor generates high destructive torques in accordance with ISO 27892. When using a vibration compensator, this will probably lead to the turbopump being sheared off in use. The energy that this would release could throw the entire turbopump or shattered pieces from its interior through the surrounding space. Potentially dangerous gases can escape. There is a risk of very serious injuries, including death, and extensive property damage.

- ▶ Take suitable safety precautions on-site for the compensation of the occurring torques.
- ▶ Before installing a vibration compensator, you must first of all contact Pfeiffer Vacuum.

Installing the vibration compensator

1. Install the vibration compensator only with vertical passage.
2. Consider the flow resistance.

3. Secure the turbopump additionally to the high vacuum flange.
4. Observe the fastening of the ISO flanges.

5.2.5 Mounting orientations

Pfeiffer Vacuum turbopumps from the HiPace series are suitable for use with dry compressing backing pumps for mounting in **all** orientations.

- ▶ When using oil-sealed backing pumps, avoid backflow from the fore-vacuum range.

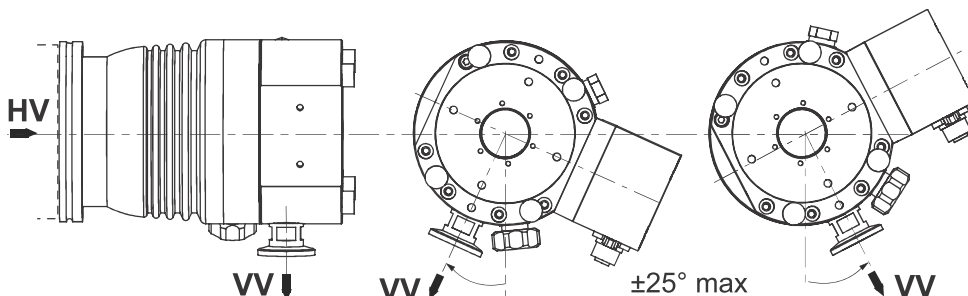

Fig. 5: Recommended alignment when using oil-sealed backing pumps

Specify a horizontal mounting orientation for oil-sealed backing pumps

1. Always align the fore-vacuum connection downwards vertically.
 - Permissible deviation $\pm 25^\circ$
2. Support the tube connections in front of the turbopump.
3. Do not allow any forces from the piping system to act on the turbopump.
4. Do not load the high vacuum flange of the turbopump on one side.

5.2.6 Installation of ISO-KF flange



ISO flange connections

For the connection of flanges in ISO-KF or ISO-K design, twisting may occur in the event of sudden blockage of the rotor, despite correct installation.

- Leak-tightness of the flange connection, however, is not jeopardized in this regard.

Required tools

- Allen key
- Calibrated torque wrench (Tightening factor ≤ 1.6)

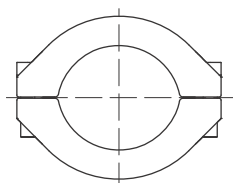

Fig. 6: Flange connection ISO-KF to ISO-KF

Using of clamping ring

1. Only use the approved mounting kits from Pfeiffer Vacuum for the connection.
2. Fasten the high vacuum connection on the turbopump and the clamping ring to the counter flange.
3. Utilize all prescribed components for the turbopump.
4. Tighten the clamping ring screws evenly.
 - Tightening torque: **3,7 Nm**.

5.2.7 Attaching ISO-K flange onto ISO-K



ISO flange connections
 For the connection of flanges in ISO-KF or ISO-K design, twisting may occur in the event of sudden blockage of the rotor, despite correct installation.

- Leak-tightness of the flange connection, however, is not jeopardized in this regard.

Required tools

- Wrench, WAF 15
- Calibrated torque wrench (Tightening factor ≤ 1.6)

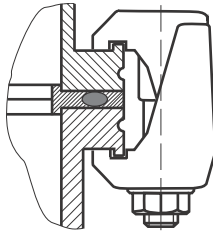

Fig. 7: Flange connection ISO-K to ISO-F, bracket screws

Connection with bracket screw

1. For the connection of the turbopump, use only the approved mounting kits from Pfeiffer Vacuum.
2. Connect the flange with the components of the mounting kit according to the figure.
3. Use for all prescribed components for the turbopump.
4. Tighten the bracket screws cross-wise in 3 steps.
 - Tightening torque: **5, 15, 25 ± 2 Nm**

5.2.8 Installation of ISO-K flange onto ISO-F

The connection types for the installation of ISO-K with ISO-F flange are:

- "Claw and tapped hole"
- "Hexagon head set screw and tapped hole"
- "Stud screw and tapped hole"
- "Stud screw and through-bore"



ISO flange connections
 For the connection of flanges in ISO-KF or ISO-K design, twisting may occur in the event of sudden blockage of the rotor, despite correct installation.

- Leak-tightness of the flange connection, however, is not jeopardized in this regard.

Connection of claw and tapped hole

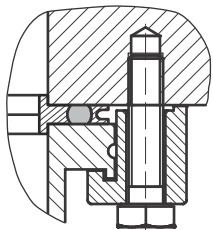

1. Only use the approved mounting kits from Pfeiffer Vacuum for the connection.
2. Connect the flange according to the diagram using the components in the mounting kit.
3. Utilize all prescribed components for the turbopump.
4. Tighten the claws in 3 stages in opposite pairs.
 - Tightening torque: **5, 10, 16 ± 1 Nm**

Connection of hexagon head set screw and tapped hole

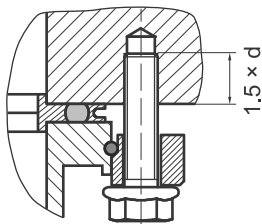

1. Only use the approved mounting kits from Pfeiffer Vacuum for the connection.
2. Place the collar flange over the high vacuum flange on the turbopump.
3. Insert the snap ring into the side groove on the high vacuum flange of the turbopump.
4. Fasten the turbopump onto the counter flange in accordance with the diagram using the collar flange, snap ring and centering ring.
5. Utilize all prescribed components for the turbopump.
6. Screw the hexagon head set screws into the tapped holes.
 - Observe the minimum tensile strength of the flange material and the screw-in depth.
7. Tighten the hexagon head set screws in 3 stages in opposite pairs.
 - Tightening torque: **5, 10, 16 ± 1 Nm**

Connection of stud screw and tapped hole

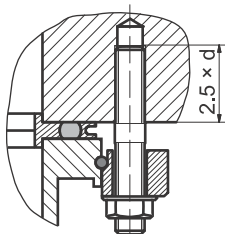

1. Only use the approved mounting kits from Pfeiffer Vacuum for the connection.
2. Screw the required number of stud screws with the shorter screw-in end into the holes in the counter flange.
 - Observe the minimum tensile strength of the flange material and the screw-in depth.
3. Place the collar flange over the high vacuum flange on the turbopump.
4. Insert the snap ring into the side groove on the high vacuum flange of the turbopump.
5. Fasten the turbopump onto the counter flange in accordance with the diagram using the collar flange, snap ring and centering ring.
6. Utilize all prescribed components for the turbopump.
7. Tighten the nuts in 3 stages in opposite pairs.
 - Tightening torque: **5, 10, 16 ± 1 Nm**

Connection of stud screw and through-bore

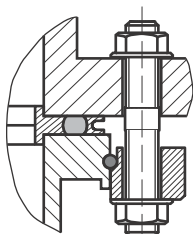

1. Only use the approved mounting kits from Pfeiffer Vacuum for the connection.
2. Place the collar flange over the high vacuum flange on the turbopump.
3. Insert the snap ring into the side groove on the high vacuum flange of the turbopump.
4. Fasten the turbopump onto the counter flange in accordance with the diagram using the collar flange, snap ring and centering ring.
5. Utilize all prescribed components for the turbopump.
6. Tighten the nuts in 3 stages in opposite pairs.
7. Tightening torque: **5, 10, 16 ± 1 Nm**

5.2.9 Attaching CF flange to CF-F

The connection types for CF installation with CF flange are:

- "Hexagon head screw and through hole"
- "Stud screw with tapped hole"
- "Stud screw with through hole"

NOTICE

Leaks may occur due to the incorrect installation of CF flanges

Inadequate cleanliness when handling CF flanges and copper gaskets results in leaks and may cause process damage.

- ▶ Always wear suitable gloves before touching or fitting any components.
- ▶ Fit seals only if dry and free of grease.
- ▶ Take care of damaged surfaces and cut edges.
- ▶ Replace the damaged components.

Required tools

- Hexagonal wrench (13 WAF)
- Calibrated torque wrench (tightening factor ≤ 1.6)

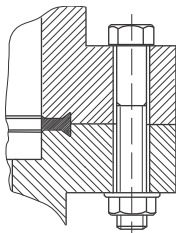

Fig. 8: Flange connection CF-F, hexagon head screw and through hole

Connection of the hexagon head screw and through holes

1. For the connection of the turbopump, use only the approved mounting kits from Pfeiffer Vacuum.
2. If used: Insert the protective screen or splinter shield with clamping lugs downwards in the turbopump high vacuum flange.
3. Place the seal exactly in the hollow.
4. Connect the flange with the components of the mounting kit according to the figure.
5. Tighten the screw couplings all the way around.
 - Tightening torque: **22 ± 2 Nm**
6. Then check the torque, since flowing of the sealing material may make it necessary to re-tighten the screws.

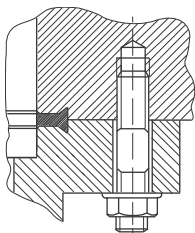

Fig. 9: Flange connection CF-F, stud screw and tapped hole

Connection of the stud screw and tapped hole

1. For the connection of the turbopump, use only the approved mounting kits from Pfeiffer Vacuum.
2. Screw in the required number of stud screws with the shorter end in the holes on the counter flange.
3. If used: Insert the protective screen or splinter shield with clamping lugs downwards in the turbopump high vacuum flange.
4. Place the seal exactly in the hollow.
5. Connect the flange with the components of the mounting kit according to the figure.
6. Tighten the screw couplings all the way around.
 - Tightening torque: **22 ± 2 Nm**
7. Then check the torque, since flowing of the sealing material may make it necessary to re-tighten the screws.

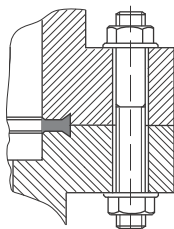

Fig. 10: Flange connection CF-F, stud screw and through hole

Connection of the stud screw and through hole

1. For the connection of the turbopump, use only the approved mounting kits from Pfeiffer Vacuum.
2. If used: Insert the protective screen or splinter shield with clamping lugs downwards in the turbopump high vacuum flange.
3. Place the seal exactly in the hollow.
4. Connect the flange with the components of the mounting kit according to the figure.
5. Tighten the screw couplings all the way around.
 - Tightening torque: **22 ± 2 Nm**
6. Then check the torque, since flowing of the sealing material may make it necessary to re-tighten the screws.

5.3 Connecting the fore-vacuum side

⚠ WARNING

Danger to life from poisoning where toxic process media leak from damaged connections

Sudden twisting of the turbopump in the event of a fault causes fittings to accelerate. There is the risk of damaging on-site connections (e.g., fore-vacuum line) and resulting leaks. This results in leakage of process media. In processes involving toxic media, there is a risk of injury and danger to life due to poisoning.

- ▶ Keep masses connected to the turbopump as low as possible.
- ▶ Use flexible lines to connect to the turbopump where necessary.



Suitable backing pump

Use the turbopump only in combination with a suitable backing pump that can deliver up to the required maximum fore-vacuum pressure. To achieve the fore-vacuum pressure, use a suitable vacuum pump or a pumping station from the Pfeiffer Vacuum range.

In this case, the backing pump is also controlled directly via the turbopump electronic drive unit interfaces (e.g., relay box or connection cable).

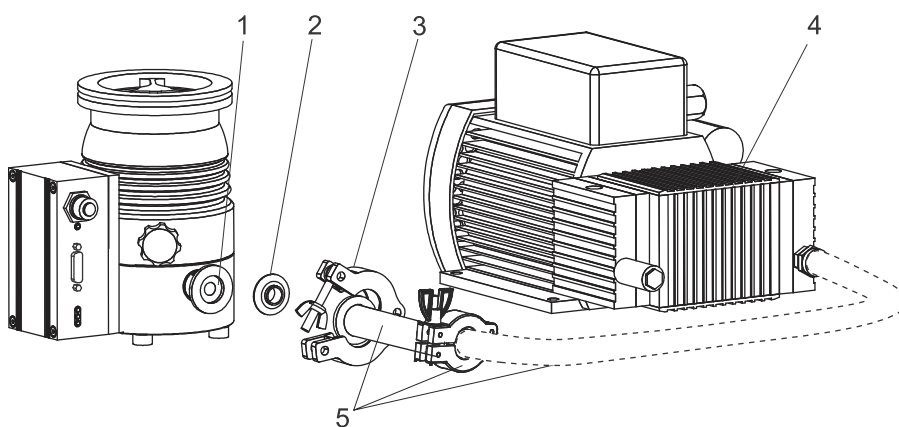

Fig. 11: Example of fore-vacuum connection on HiPace 80

- | | |
|------------------------------------|---------------------------------------|
| 1 Turbopump fore-vacuum connection | 4 Backing pump (e.g., diaphragm pump) |
| 2 Centering ring | 5 Vacuum components DN 16 ISO-KF |
| 3 Circlip | |

Establishing the fore-vacuum connection

1. With rigid pipe connections, include bellows to attenuate external vibrations.
2. Install a fore-vacuum connection with small flange components, e.g., fasteners and pipe components DN 16 ISO-KF, from the [Pfeiffer Vacuum Components Shop](#).
3. Implement measures to counteract the backflow of operating fluids or condensate from the fore-vacuum area.
4. Observe the information in the operating instructions of the backup pump or pumping station when connecting and operating it.

5.4 Connecting accessories



Installation and operation of accessories

Pfeiffer Vacuum offers a series of special, compatible accessories for its products.

- Information and ordering options for approved [accessories for hybrid bearing turbo-pumps](#) can be found online.



Connect accessory devices to the TC 110

- The use of Pfeiffer Vacuum accessories via the TC 110 electronic drive unit is only possible using the corresponding connection cable and/or adapter on the X3 multifunctional connection.
- Configure the required accessory output via RS-485 using Pfeiffer Vacuum display and control units or PC.

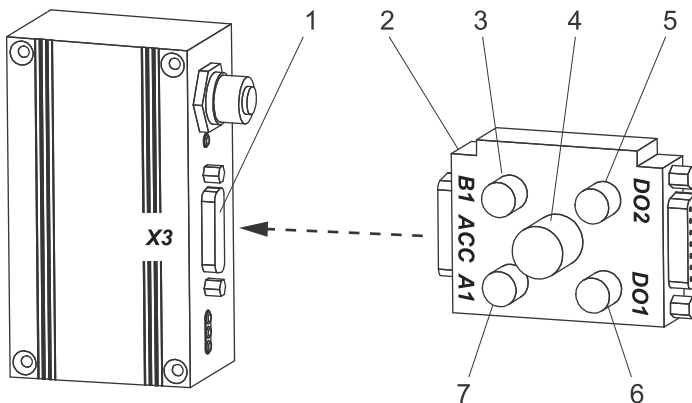

Fig. 12: Example of accessory connection via adapter TCS 12

- | | |
|-------------------------------|---------------------------|
| 1 Multifunction connection X3 | 5 Digital output DO2 |
| 2 Adapter TCS | 6 Digital output DO1 |
| 3 Accessory connection B1 | 7 Accessory connection A1 |
| 4 Connection RS-485 | |

Connecting pre-configured accessories

- ▶ Observe the installation instructions in the operating instructions for the relevant accessory.
- ▶ Note the existing configuration of existing connections and control lines.
- ▶ Connect only matching accessory devices to the electronic drive unit.

Using additional accessories

- ▶ Observe the installation instructions in the operating instructions for the relevant accessory.
- ▶ Note the existing configuration of existing connections and control lines.
- ▶ Use the Pfeiffer Vacuum display and control unit DCU 002, or a DCU with integrated power supply pack.

5.5 Connecting the electrical supply

⚠ WARNING

Risk of danger to life through missing mains disconnection device

The vacuum pump and electronic drive unit are **not** equipped with a mains disconnection device (mains switch).

- ▶ Install a mains disconnection device according to SEMI-S2.
- ▶ Install a circuit breaker with an interruption rating of at least 10,000 A.

⚠ WARNING

Risk of injury due to incorrect installation

Dangerous situations may arise from unsafe or incorrect installation.

- ▶ Do not carry out your own conversions or modifications on the unit.
- ▶ Ensure the integration into an Emergency Off safety circuit.

5.5.1 Earthing the turbopump

Pfeiffer Vacuum recommends connecting a suitable grounding cable to discharge applicative interferences.

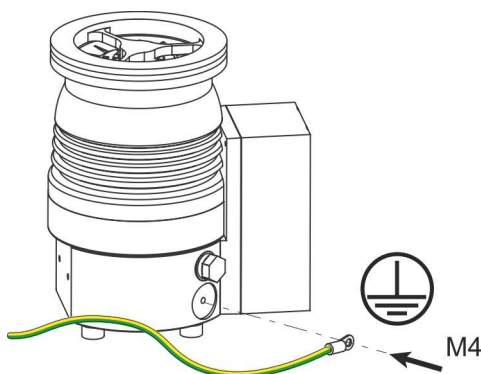

Fig. 13: Example: Connecting the grounding cable

Procedure

1. Use the turbopump ground terminal (M4 female thread).
2. Route the connection in accordance with locally applicable provisions.

5.5.2 Establishing the electric connection

⚠ DANGER

Danger to life from electric shock

Power supply packs that are not specified or are not approved will lead to severe injury to death.

- ▶ Make sure that the power supply pack meets the requirements for double isolation between mains input voltage and output voltage, in accordance with IEC 61010 and IEC 60950.
- ▶ Make sure that the power supply pack meets the requirements in accordance with IEC 61010 and IEC 60950.
- ▶ Where possible, use original power supply packs or only power supply packs that correspond with the applicable safety regulations.

⚠ WARNING

Danger of cut injuries from unexpected start up.

The use of mating plugs of the electronic drive unit (accessories) enables the automatic run-up of the vacuum pump as soon the power is turned on. Attaching mating plugs before or during the installation leads to the movement of parts hence the risk of cut injuries by sharp-edged in the exposed high vacuum flange.

- ▶ Only connect mating plugs after the mechanical installation.
- ▶ Only switch on the vacuum pump immediately prior to operation.

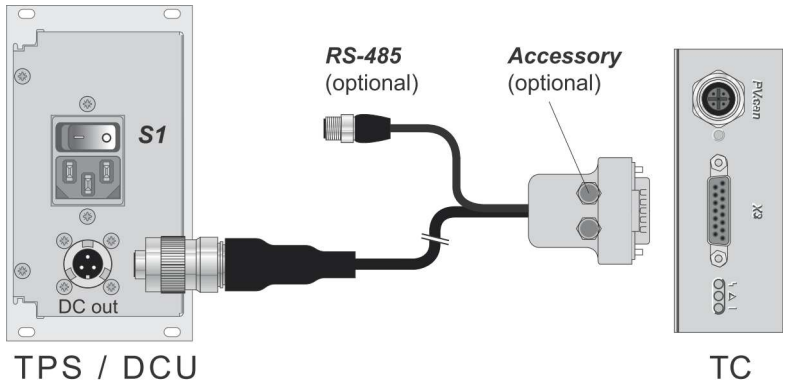

Fig. 14: Connecting the electronic drive unit to a power supply pack

Original power supply packs (e.g. TPS 110 or DCU 110) and connection cable are available for electronic drive unit TC 110 voltage supply.

Type of connection cable	Function
Connection cable with RS-485 interface and bridges from TC 110 TC 120 to power supply unit	<ul style="list-style-type: none"> • Power supply via power supply unit • Automatic startup via bridges on pins 2, 5, 7 • Connection to display and control unit via RS-485
Connection cable with RS-485 interface and accessory connections from TC 110 TC 120 to power supply unit	<ul style="list-style-type: none"> • Power supply via power supply unit • Connection of accessory devices with M8 plug • Connection to display and control unit via RS-485
Connection bridges from TC 110 TC 120 to power supply unit	<ul style="list-style-type: none"> • Power supply via power supply unit • Automatic startup via bridges on pins 2, 5, 7
Connection cable with bridges and accessory connections from TC 110 TC 120 to power supply unit	<ul style="list-style-type: none"> • Power supply via power supply unit • Automatic startup via bridges on pins 2, 5, 7 • Connection of accessory devices with M8 plug

Connecting the electronic drive unit

1. Make sure that you have the correct supply voltage.
2. Make sure that the “S1” power supply pack master switch is off prior to connection.
3. Plug the 15-pole connection cable plug into the “X3” connection on the electronic drive unit and secure it.
4. Plug the connecting socket with the bayonet catch into the “DC out” connection on the power supply pack, and lock it.
5. **When using a display and control unit:** Connect the “RS-485” connector of a suitable connection cable to the display and control unit.

6 Operation

6.1 Commissioning

WARNING

Danger of cut injuries from unexpected start up.

The use of mating plugs of the electronic drive unit (accessories) enables the automatic run-up of the vacuum pump as soon the power is turned on. Attaching mating plugs before or during the installation leads to the movement of parts hence the risk of cut injuries by sharp-edged in the exposed high vacuum flange.

- ▶ Only connect mating plugs after the mechanical installation.
- ▶ Only switch on the vacuum pump immediately prior to operation.

NOTICE

Vacuum pump destruction due to excessive energy input during operation

Simultaneous loading by means of high drive power (gas throughput, fore-vacuum pressure), high heat radiation, or strong magnetic fields results in uncontrolled heating of the rotor and can destroy the vacuum pump.

- ▶ Consult Pfeiffer Vacuum before combining varying loads on the vacuum pump. Lower limit values apply.

NOTICE

Turbopump destruction due to gases with too high molecular masses

The pumping of gases with impermissible high molecular masses leads to the destruction of the turbopump.

- ▶ Make sure that the gas mode is set correctly by **[P:027]** in the electronic drive unit.
- ▶ Consult Pfeiffer Vacuum before you use gases with higher molecular masses (> 80).

Important settings and function-related variables are factory-programmed into the vacuum pump electronic drive unit as parameters. Each parameter has a three-digit number and a description. Parameter-driven operation and control is supported via Pfeiffer Vacuum displays and control units, or externally via RS-485 using Pfeiffer Vacuum protocol.

Parameter	Name	Designation	Adjustment, setting
[P:027]	GasMode	Gas mode	0 = heavy gases
[P:035]	CfgAccA1	Accessory connection A1	0 = fan (continuous operation)
[P:036]	CfgAccB1	Accessory connection B1	1 = venting valve
[P:700]	RUTimeSVal	Set value run-up time	8 min.
[P:701]	SpdSwPt1	Rotation speed switch point 1	80 %
[P:707]	SpdSVal	Speed-control operation specification	65 %
[P:708]	PwrSVal	Set value power consumption	100 %
[P:720]	VentSpd	Venting at rotation speed, delayed venting	50 %
[P:721]	VentTime	Venting time, delayed venting	3600 s

Tbl. 7: Factory setting of the electronic drive unit for turbopumps when delivered

Notes for turbopump commissioning

1. When using water cooling, observe the cooling water flow and throughput.
2. When using sealing gas, observe the sealing gas flow and throughput.
3. Provide the current supply for the power supply pack.

6.2 Operating modes

The turbopump can be operated in different modes.

- Operation without control unit
- Operation via connection "E74"
- Operation via "remote" connection
- Operation via interface RS-485 and Pfeiffer Vacuum display and control unit or PC
- Operation via field bus

6.2.1 Operation without operating unit



Automatic start

The turbopump starts up immediately on bridging the pin 2, 5, 7 contacts on the "X3" connection or using the a connection cable "with bridges" and running the supply voltage.

Notes on operation without control unit

1. Only use the approved Pfeiffer Vacuum connection cables with bridges on the "X3" connection on the electronic drive unit.
2. Only switch on the power supply of the turbopump immediately before operation.

After applying the operating voltage, the electronic drive unit carries out a self-test to check the supply voltage. After completing the self-test successfully, the turbopump starts and activates connected additional equipment according to the configuration.

6.2.2 Operation via multi-function connection "X3"

Remote control is available via the 15 Pole D-Sub connection with the "X3" designation on the electronic drive unit. The accessible individual functions are mapped to "PLC levels".

Instructions for remote control operation

- ▶ See the electronic drive unit operating instructions.

6.2.3 Operation via Pfeiffer Vacuum display and control unit

The connection of a Pfeiffer Vacuum display and control panel permits the controlling of the turbopump via the parameters fixed in the electronic drive unit.

Instructions for operation with display and control unit

1. When handling the Pfeiffer Vacuum display and control unit, observe the associated operating instructions:
 - "DCU" operating instructions available from the [Download Center](#).
 - "HPU" operating instructions available from the [Download Center](#).
2. Observe the electronic drive unit operating instructions from the turbopump scope of delivery.
3. Connect the "RS-485" connector of a suitable connection cable to the DCU.
4. Switch on the turbopump current supply via the external power supply pack or the DCU with integrated power supply pack.

6.2.4 Operation via field bus

Integrating and operating Pfeiffer Vacuum turbopumps in the customer's field bus system is possible when using an electronic drive unit with a corresponding connection panel.

The following are available:

- Profibus

Instructions for field bus operation

- ▶ See the operating manual of the electronic drive unit with corresponding connection panel.

6.3 Switching on the turbopump

WARNING

Danger of cut injuries from unexpected start up.

The use of mating plugs of the electronic drive unit (accessories) enables the automatic run-up of the vacuum pump as soon the power is turned on. Attaching mating plugs before or during the installation leads to the movement of parts hence the risk of cut injuries by sharp-edged in the exposed high vacuum flange.

- ▶ Only connect mating plugs after the mechanical installation.
- ▶ Only switch on the vacuum pump immediately prior to operation.

WARNING

Risk of burns on hot surfaces when using additional equipment for heating during operation

The use of additional equipment for heating the vacuum pump or for optimizing the process generates very high temperatures on surfaces that can be touched. There is a risk of burning.

- ▶ If necessary, set up a contact guard.
- ▶ If necessary, apply the warning stickers provided for this at the danger points.
- ▶ Ensure adequate cooling down before working on the vacuum pump or in its vicinity.
- ▶ Wear protective equipment, e.g., gloves.

WARNING

Risk of serious injury in the event of vacuum pump destruction due to over pressure

Gas entry with very high over pressure results in destruction of the vacuum pump. There is a risk of serious injury due to ejected objects.

- ▶ Never exceed the permissible 1500 hPa (absolute) inlet pressure on the suction side or the venting and sealing gas connection.
- ▶ Make sure that high, process-related over pressures cannot directly enter the vacuum pump.







Switching on the turbopump





- ▶ Connect the power supply pack to the mains power supply on the customer-side.
- ▶ Switch on the power supply pack.

6.4 Operation monitoring

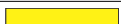
6.4.1 Operating mode display via LED

LEDs on the electronic drive unit show the basic operating states of the vacuum pump. A differentiated error and warning display is only possible for operation with the Pfeiffer Vacuum display and control unit or a PC.

LED	Symbol	LED status	Display	Meaning
Green 		Off	—	Currentless
		On, flashing		"pumping station OFF", rotation speed ≤ 60 rpm
		On, inverse flashing		"pumping station ON", set rotation speed not reached
		On, constant		"pumping station ON", set rotation speed reached
		On, flashing		"pumping station OFF", speed > 60 rpm
Yellow 	△	Off	—	No warning
		On, constant		Warning

LED	Symbol	LED status	Display	Meaning
Red 		Off		No error, no warning
		On, constant		Error, malfunction

Tbl. 8: Behavior and meaning of the LEDs on the electronic drive unit

6.4.2 Temperature monitoring

If threshold values are exceeded, output signals from temperature sensors bring the turbopump to a safe condition. Depending on the type, temperature thresholds for warning and error messages are immutably stored in the electronic drive unit. For information purposes, various status requests are set up in the parameter set.

- In order to avoid switching off the turbopump, the electronic drive unit already reduces the power consumption in case of exceeding the warning threshold for excess temperature.
 - Examples are an impermissible motor temperature, or impermissibly high housing temperature.
- Further reduction of drive power and thus decreasing speed can potentially lead to underrun the rotation speed switchpoint. The turbopump switches off.
- Exceeding the temperature threshold for error messages switches off the turbopump immediately.

6.5 Switching off and venting



We recommend

Vent the turbopump after shutdown. By doing so, you prevent particles flowing back into the vacuum system from the fore-vacuum area.

6.5.1 Switching off

Notes for switching off the turbopump

1. Shut down the turbopump via the control unit or remote control.
2. Close the fore-vacuum line.
3. Switch off the backing pump, if necessary.
4. Vent the turbopump (options see below).
5. Close the supply lines (e.g. for cooling water or sealing gas).

6.5.2 Venting

⚠ CAUTION

Risk of injuries due to contact with vacuum when venting

While venting the vacuum pump there is a risk of minor injuries due to the direct contact of body parts with the vacuum, e.g. hematomas.

- ▶ Do not fully unscrew the venting screw out of the housing during venting.
- ▶ Keep a distance from automatic venting device, such as venting valves.

NOTICE

Damage to the turbopump due to non-permissibly fast pressure rise during venting

Non-permissibly high pressure rise rates place a significant load on the rotor and the magnetic bearing of the turbopump. During venting very small volumes in the vacuum chamber or the turbopump, there is a risk of uncontrollable pressure rises. This causes mechanical damage to the turbopump, including potential failure.

- ▶ Observe the prescribed maximum pressure rise speed of **15 hPa/s**.
- ▶ Avoid manual and uncontrolled venting of very low volumes.
- ▶ Where necessary, use a venting valve from the Pfeiffer Vacuum range of accessories.